



ترمودینامیک

Thermodynamics

کاربردها
Applications

What is Thermodynamics?

- Thermodynamics is a branch of physics which deals with the energy and work of a system.
- It was born in the 19th century as scientists were first discovering how to build and operate steam engines.
- Thermodynamics deals only with the large scale response of a system which we can observe and measure in experiments.
- Small scale gas interactions are described by the kinetic theory of gases.
- The methods complement each other; some principles are more easily understood in terms of thermodynamics and some principles are more easily explained by kinetic theory.

Thermodynamics Concepts

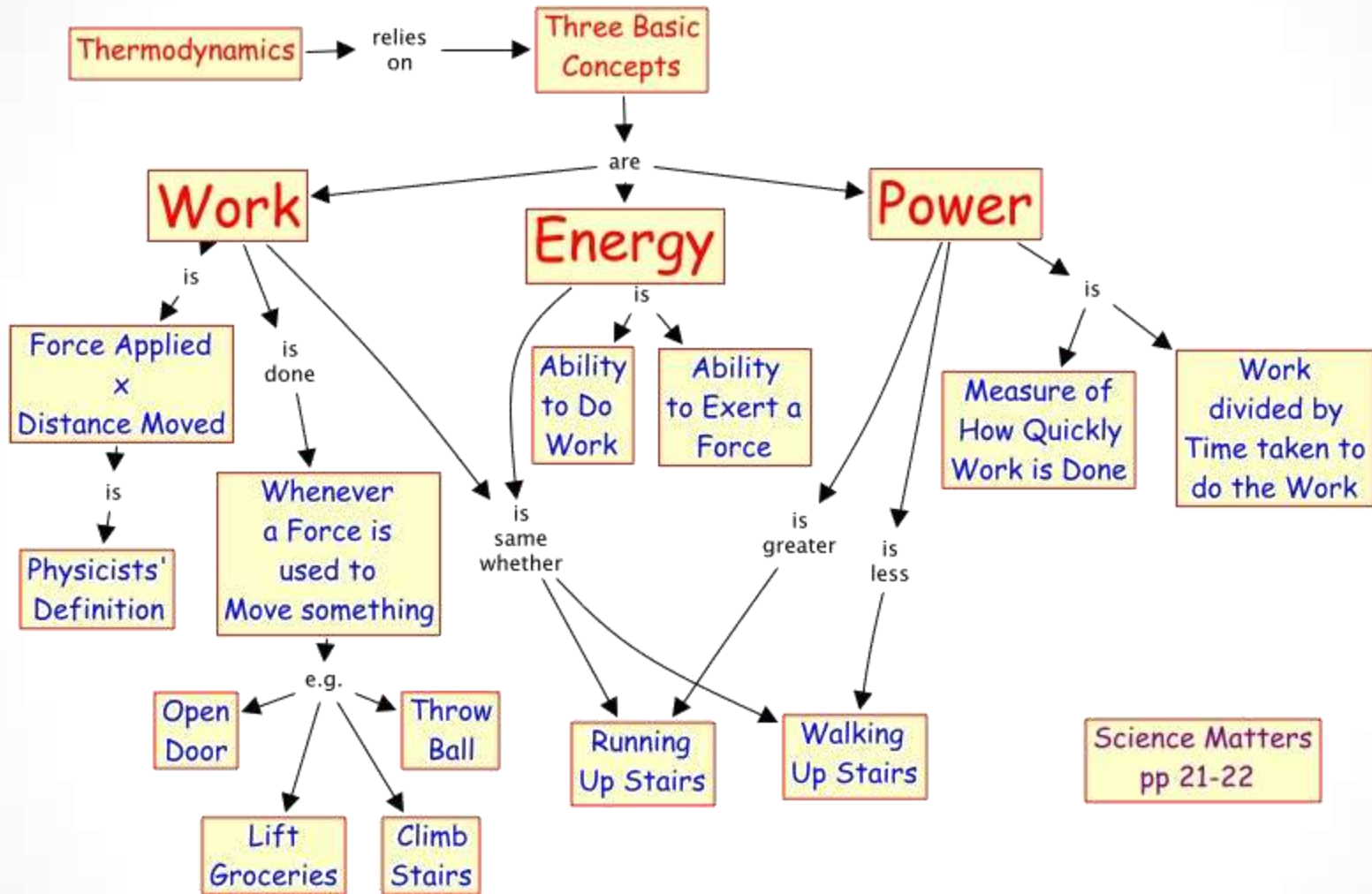

Science Matters
pp 21-22

Thermodynamics Concepts

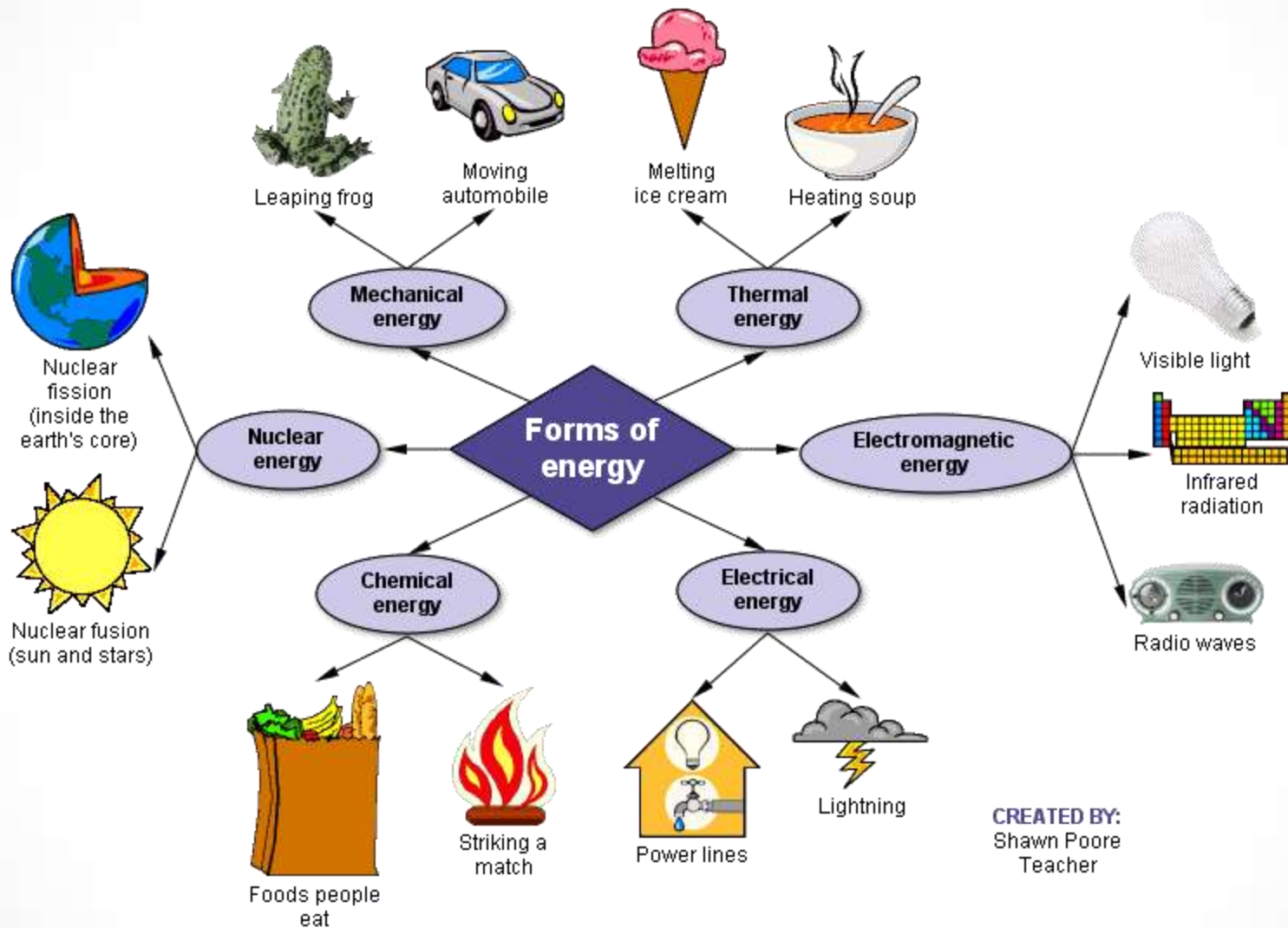

CREATED BY:
Shawn Poore
Teacher

- **Work**- equal to the constant force exerted on an object in the direction of motion times the object's displacement
- **Energy**- the ability of an object to produce change in itself or the world around it
- **Kinetic energy**- equal to $1/2$ times the mass of an object multiplied by the velocity of an object squared
- **Joule**- unit of energy equal to a Newton times a meter
- **Power**- equal to work done divided by the time it takes to do the work
- **Watt**- unit of power equal to 1 Joule/1 second
- **Rotational kinetic energy**- equal to $1/2$ times the moment of inertia of the object times the rotational velocity squared
- **Gravitational potential energy**- equal to the product of its mass, the acceleration due to gravity, and the distance from the reference level
- **Reference level**- the position where potential energy is defined to be zero
- **Elastic potential energy**- stored energy is an object with tension or elastic qualities
- **Law of conservation of energy**- in a closed system, energy can not be created or destroyed
- **Mechanical energy**- sum of kinetic energy and gravitational potential energy of a system
- **Thermal energy**- heat energy
- **Elastic collision**- collision in which kinetic energy does not change
- **Inelastic collision**- collision in which kinetic energy increases

Applications

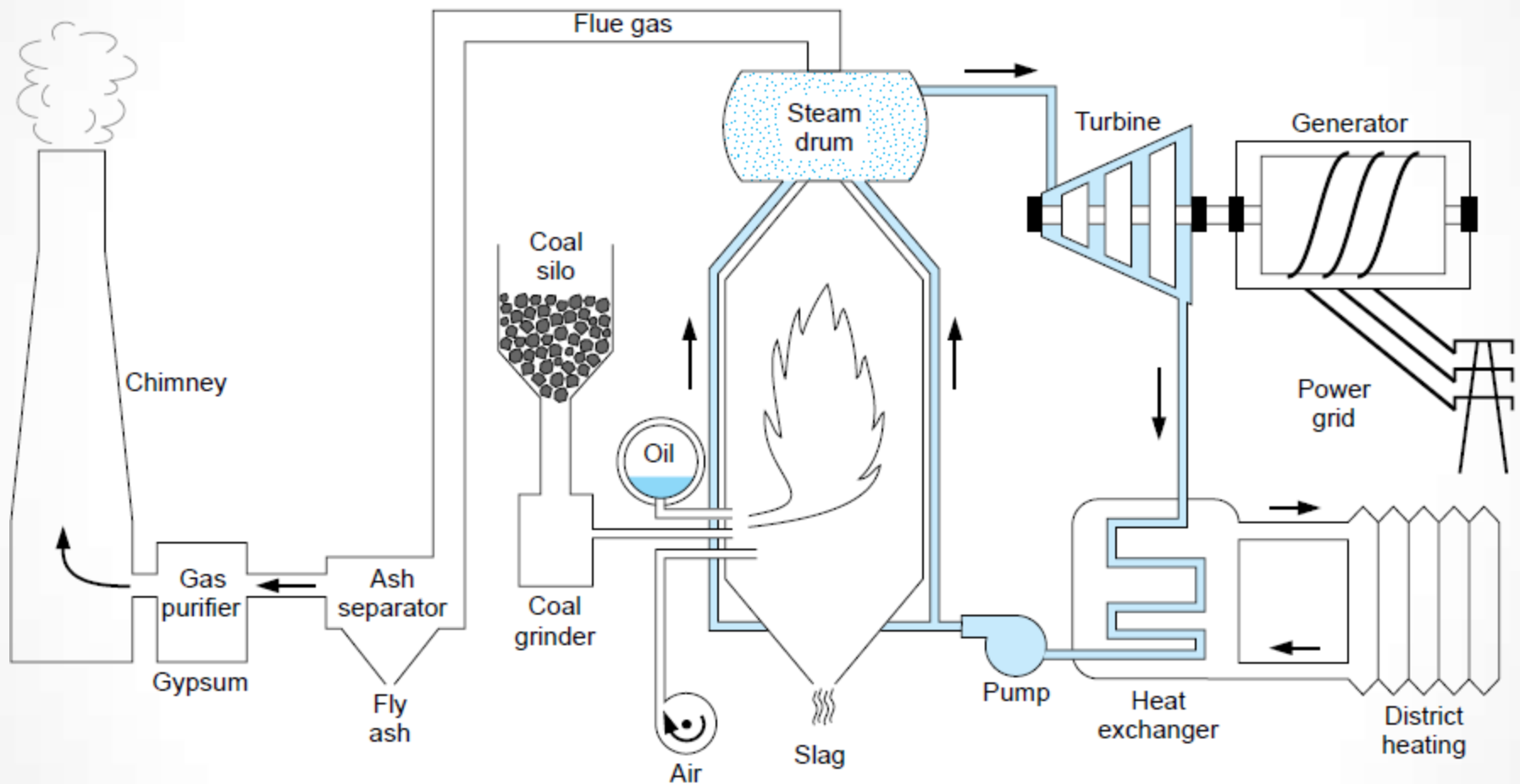

Schematic diagram of a steam power plant

Applications



The Esbjerg, Denmark, power station

Applications

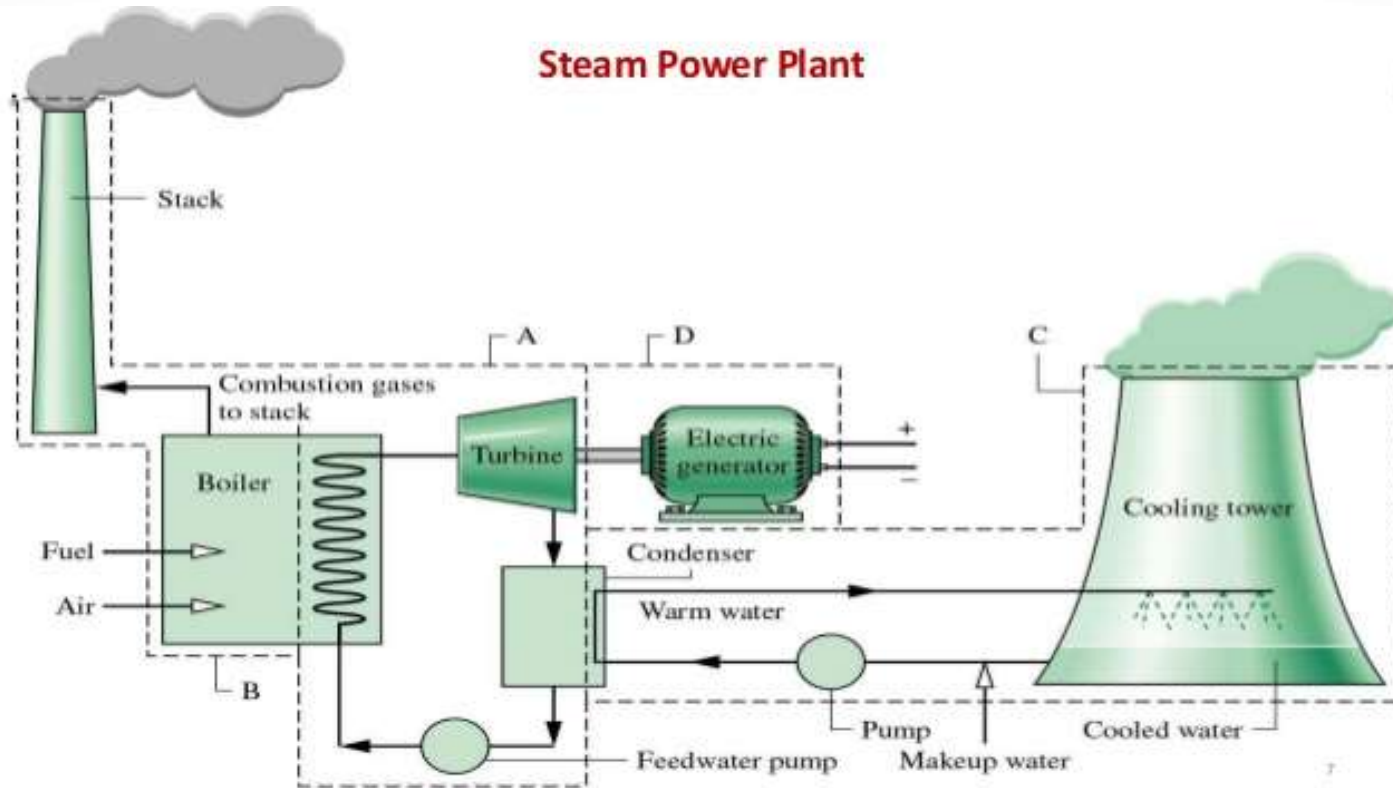

Applications

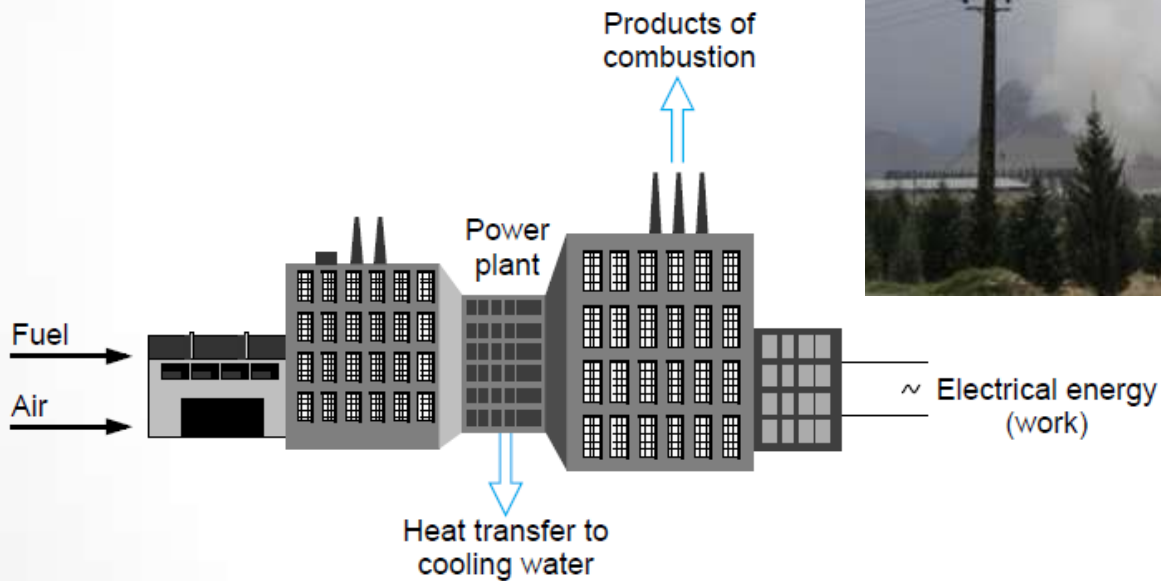

Schematic diagram of a power plant.

Applications

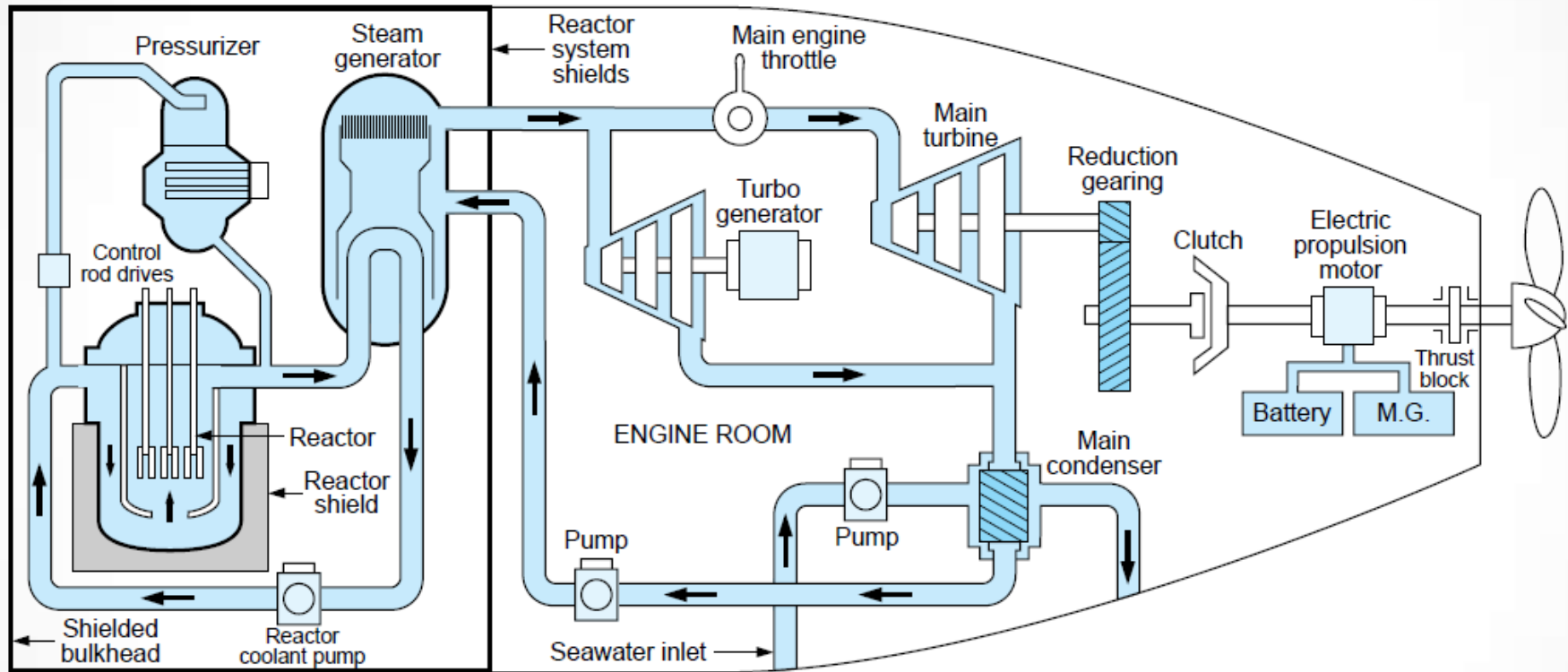

Schematic diagram of a shipboard nuclear propulsion system.

Applications

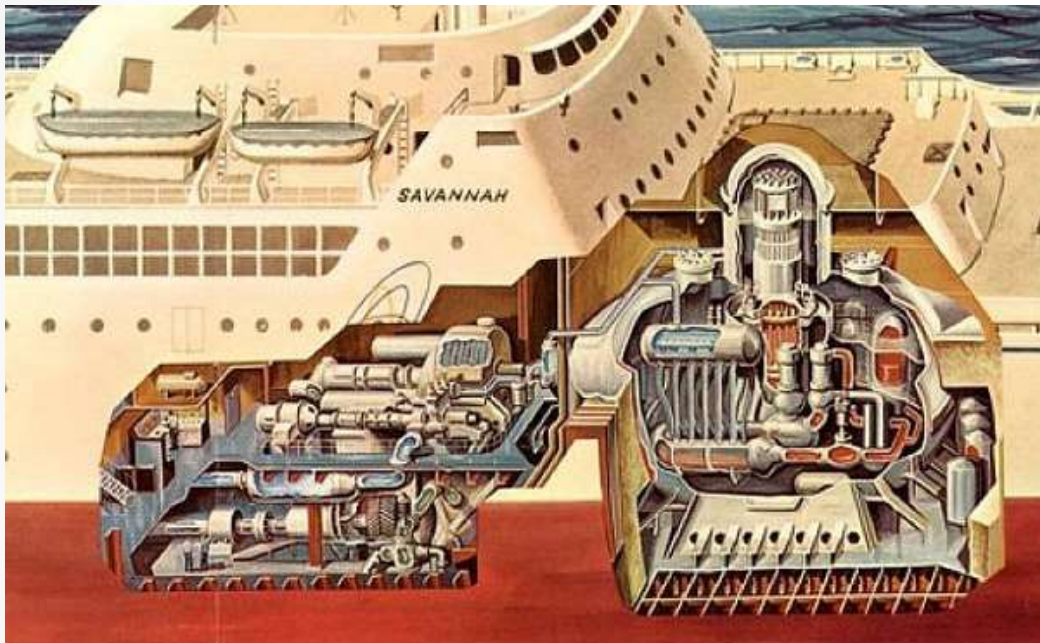

Nimitz-class supercarriers



USS Enterprise

Applications

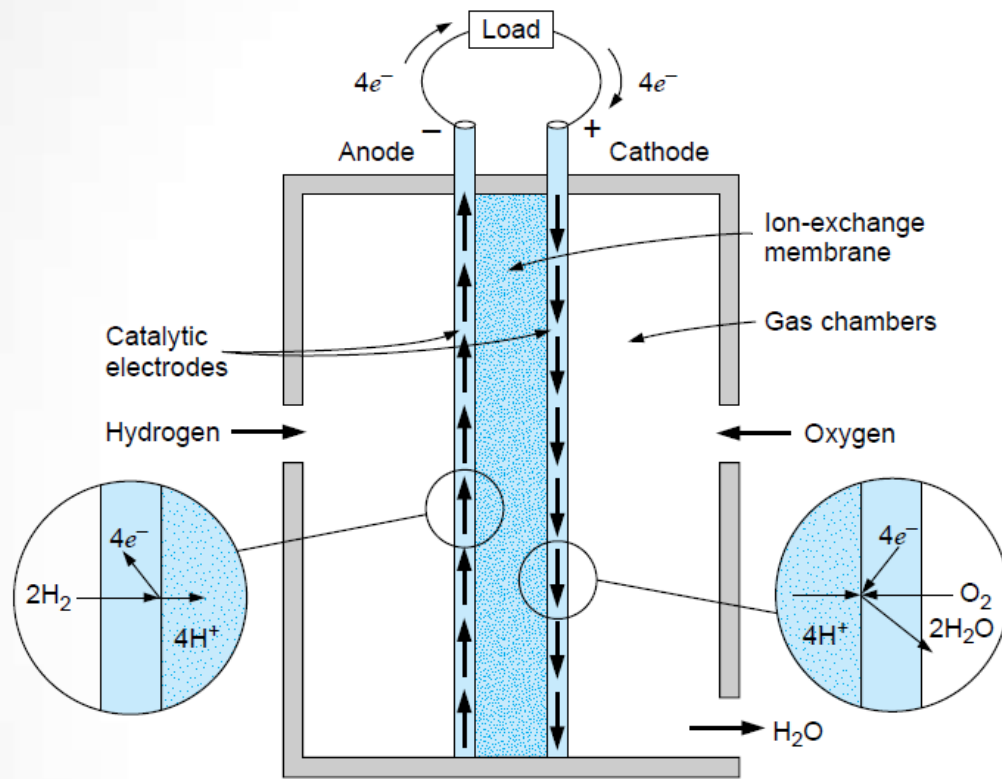

Schematic arrangement of an ion-exchange membrane type of fuel cell.

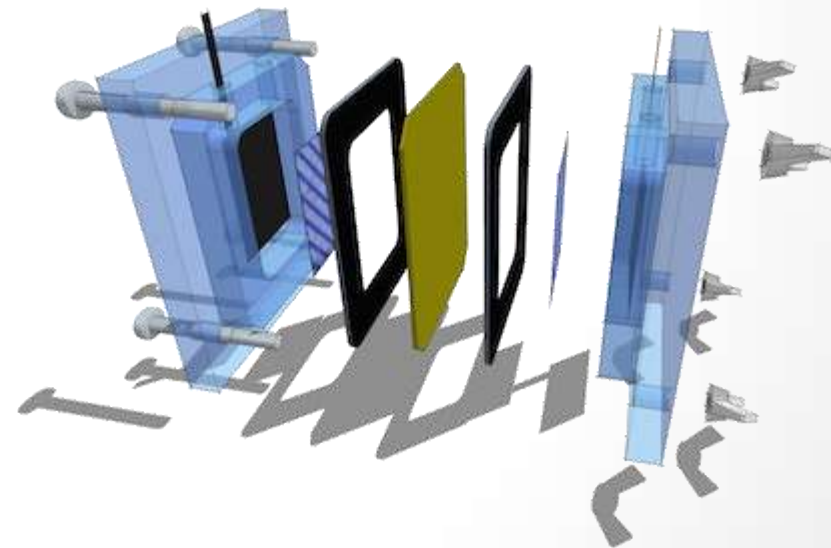

Applications

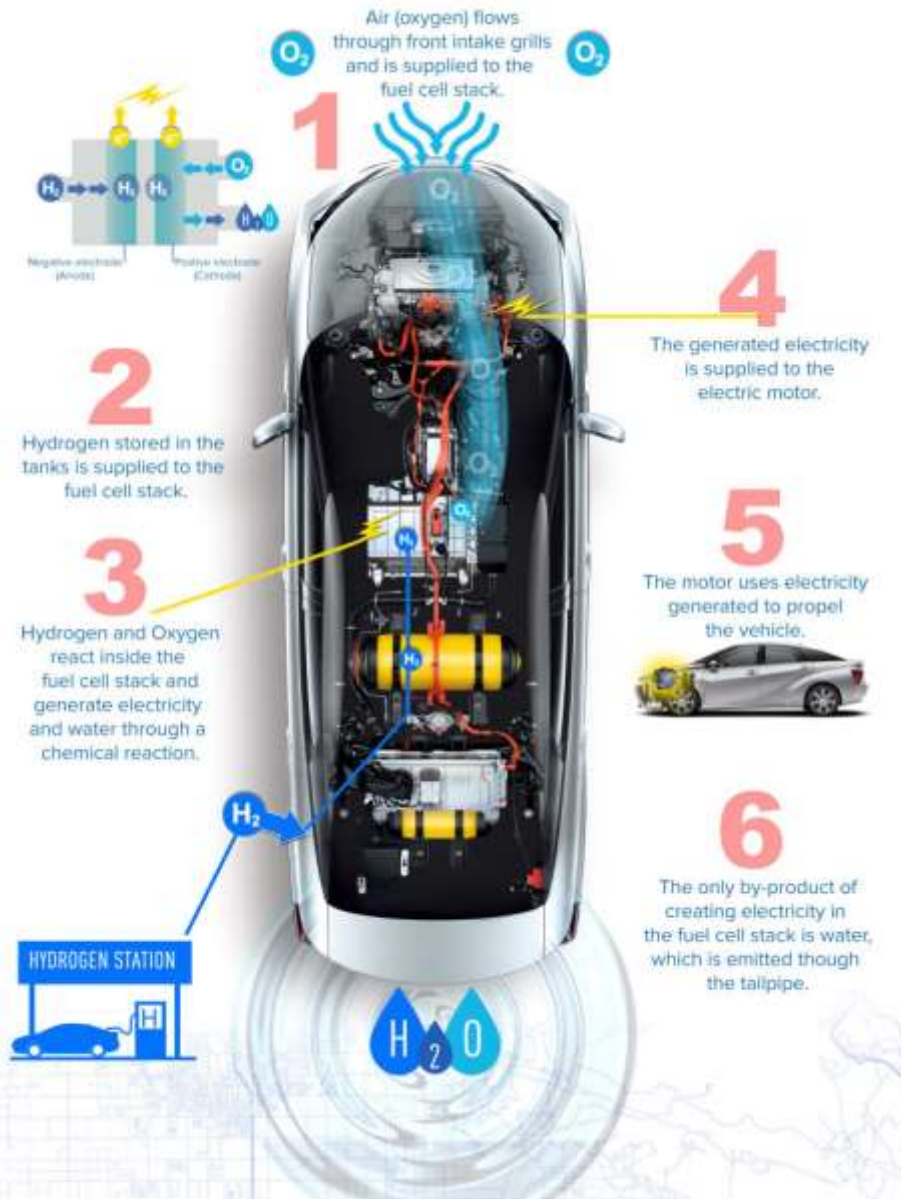

Applications

Fuel cell technology explained

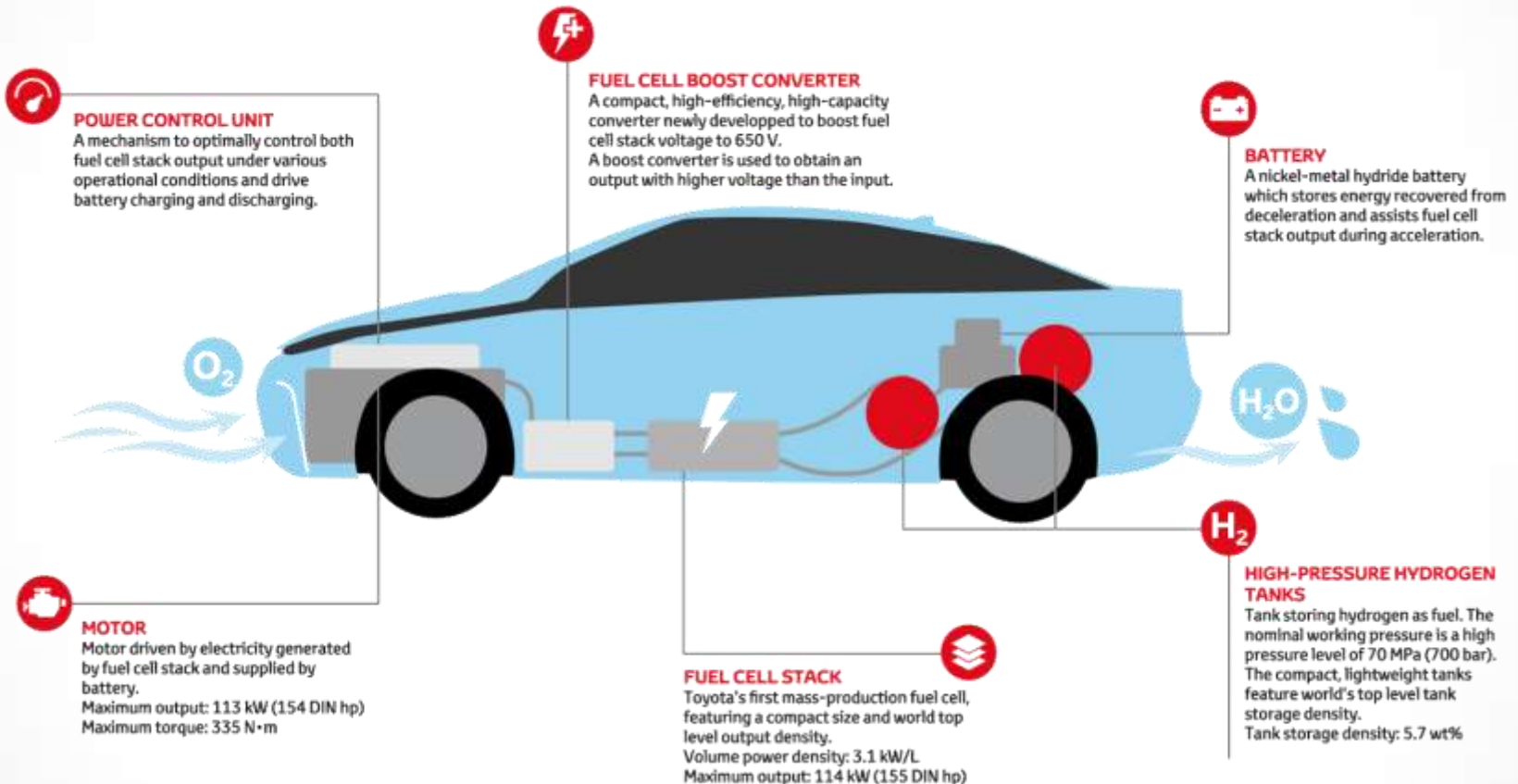

Applications

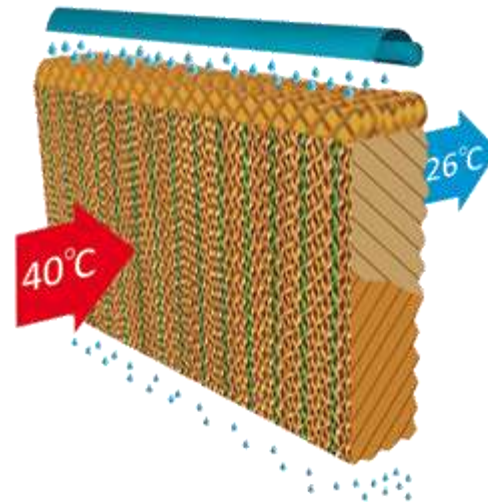

Applications

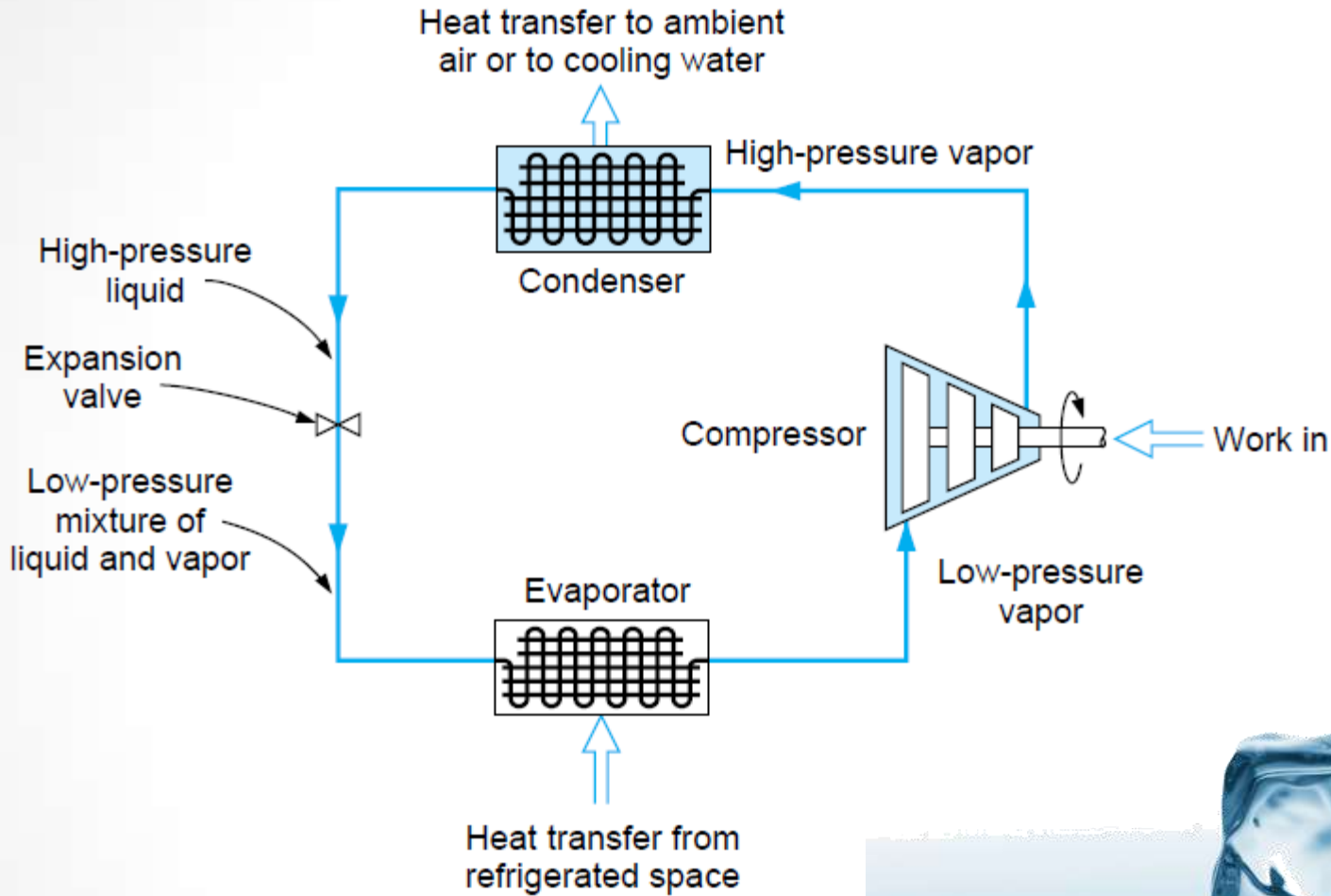

Schematic diagram of a simple refrigeration cycle.



Applications

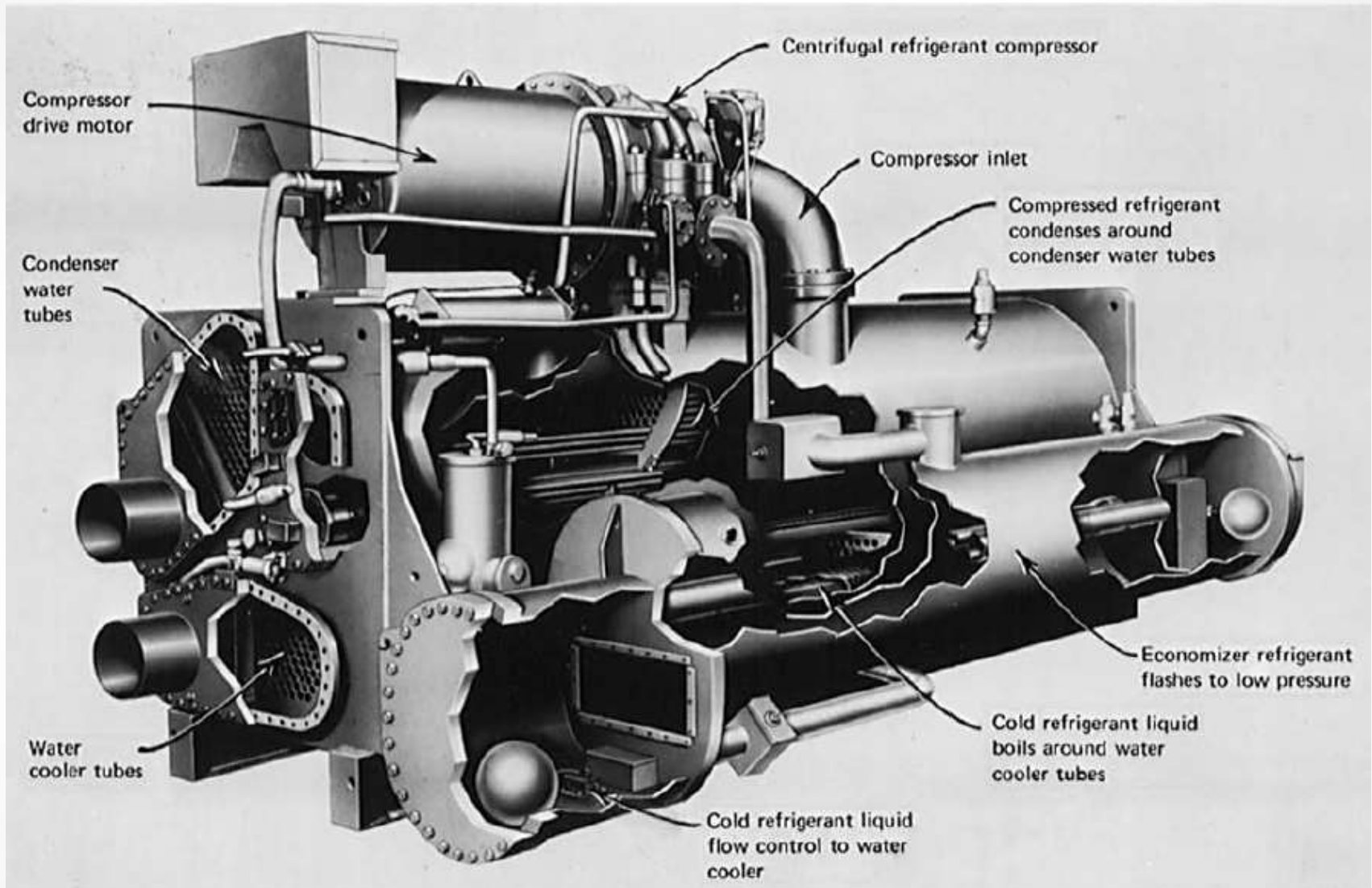

A refrigeration unit for an air-conditioning system.

Applications

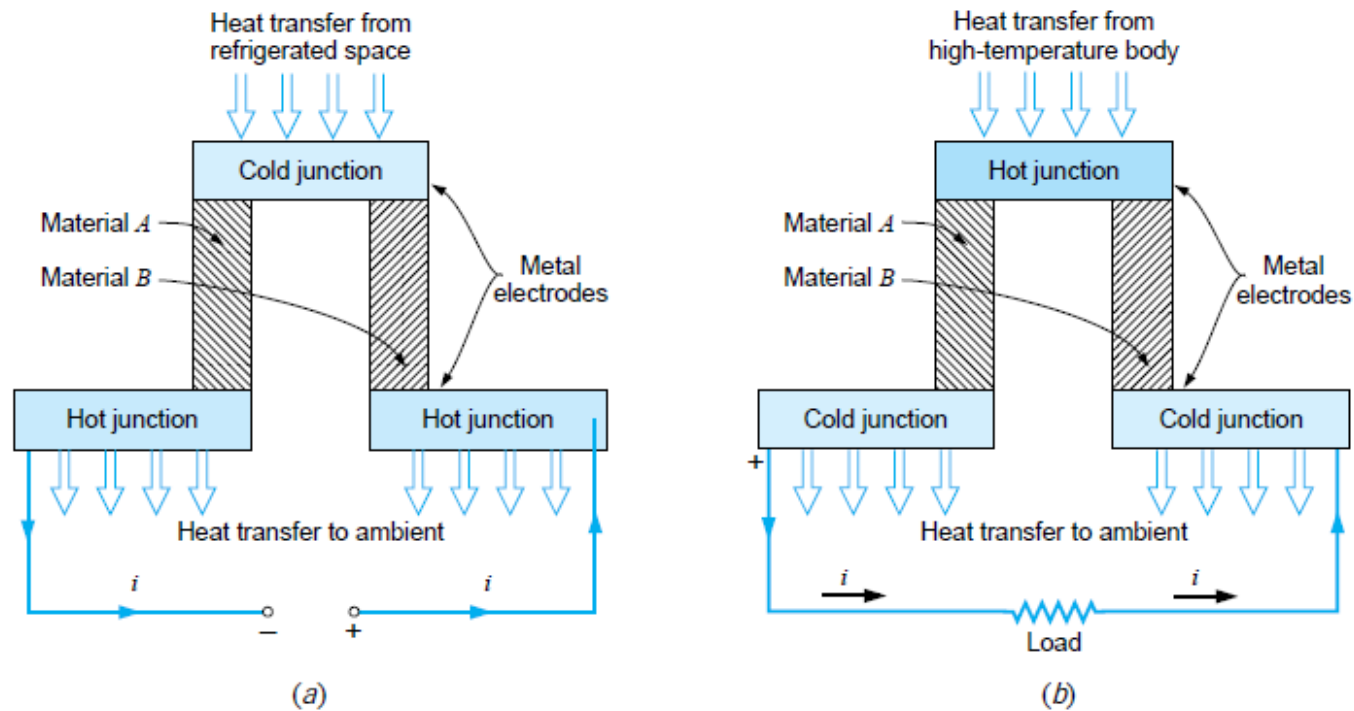

(a) A thermoelectric refrigerator. (b) A thermoelectric power generation device.

Applications

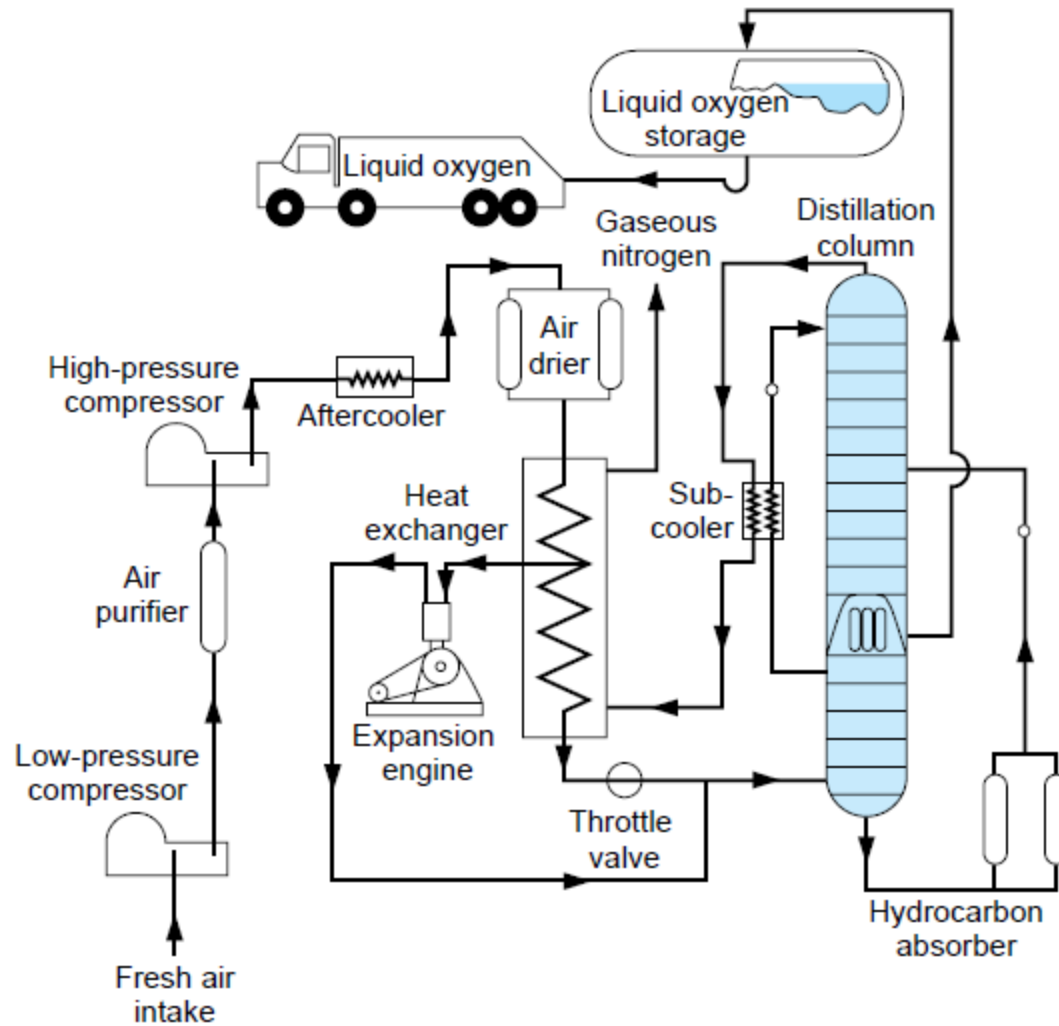

simplified diagram of a liquid oxygen plant.

Applications

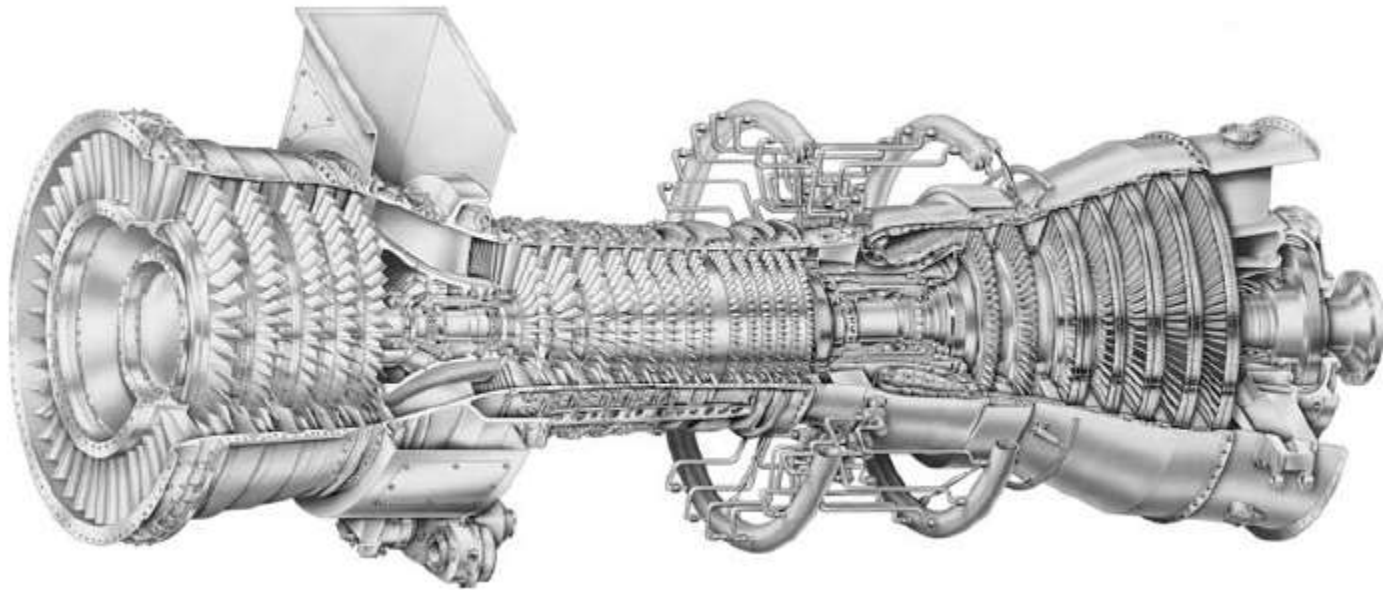

43 MW gas turbine.
(Courtesy General
Electric Corporation.)

Applications

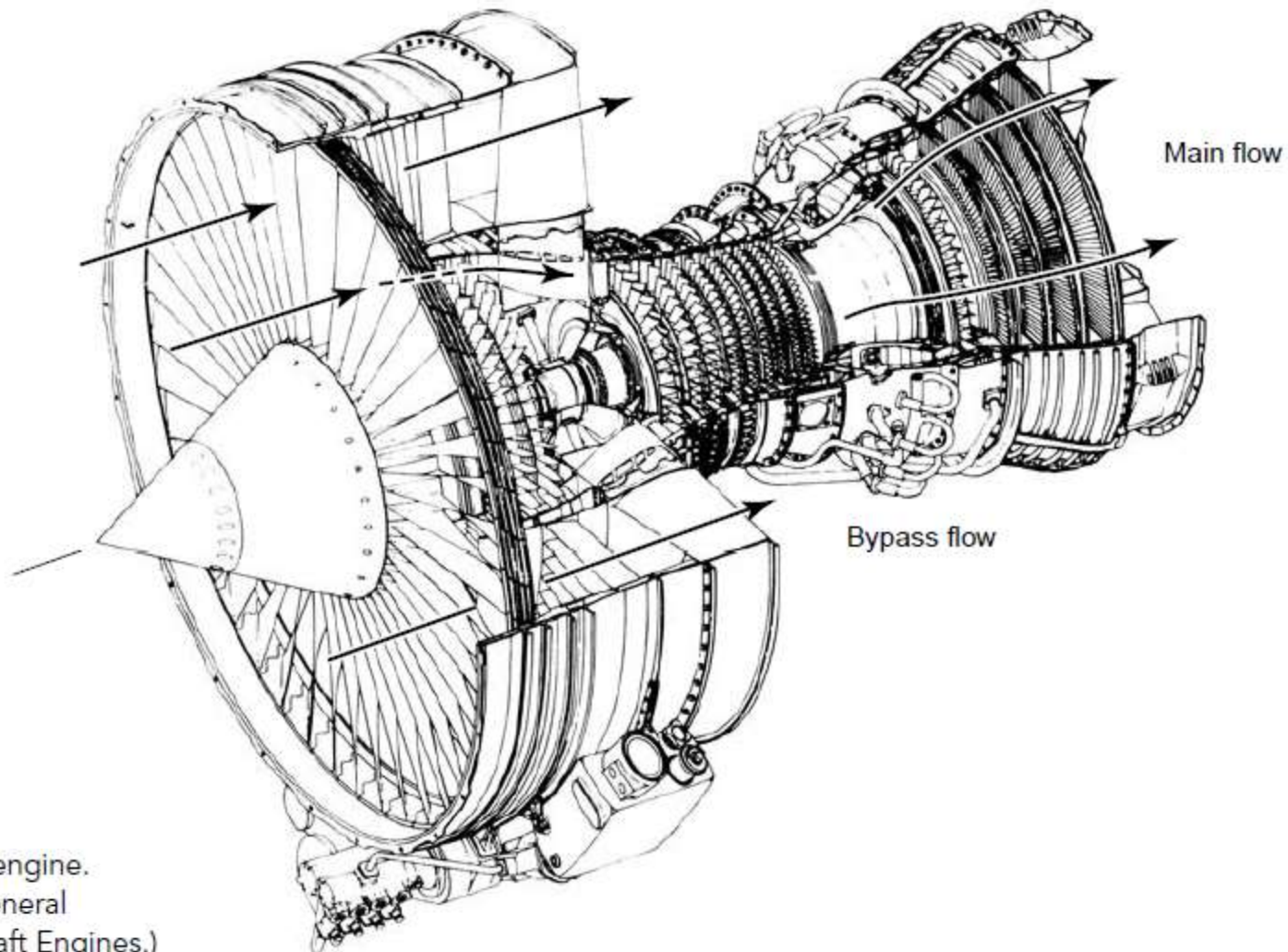

turbofan jet engine.
(Courtesy General
Electric Aircraft Engines.)

Applications

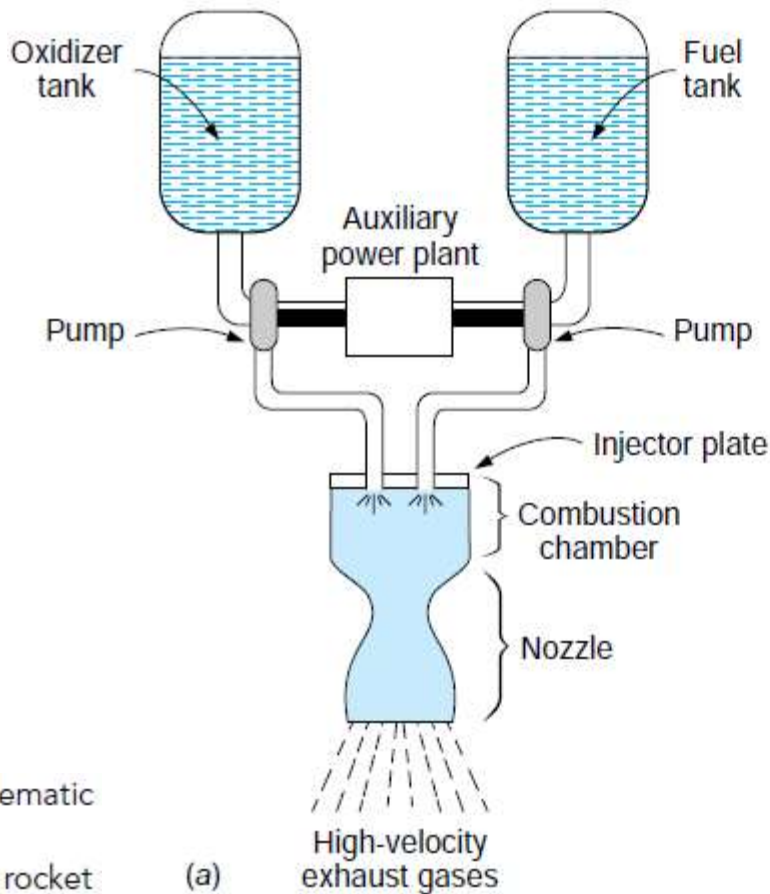

(a) Simplified schematic diagram of a liquid-propellant rocket engine. (b) Photo of the NASA space shuttle's main engine.



Water wheel

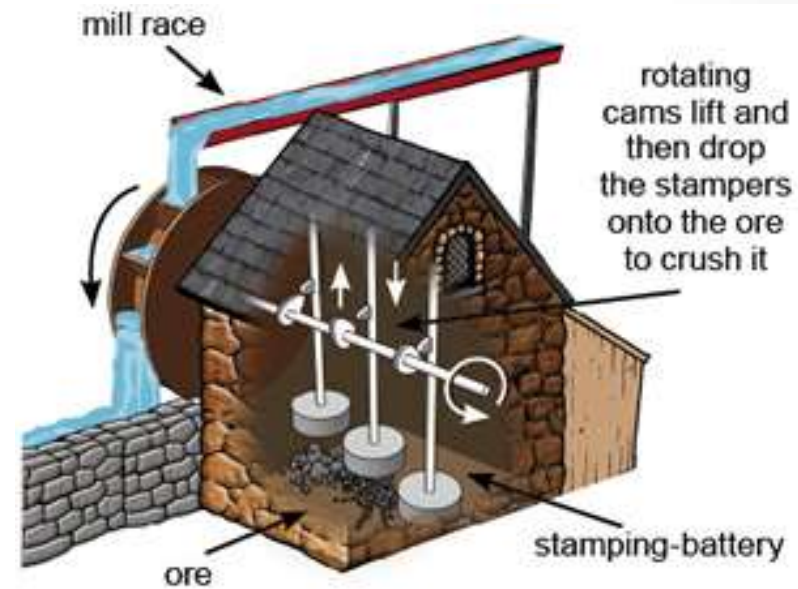

Water turbine

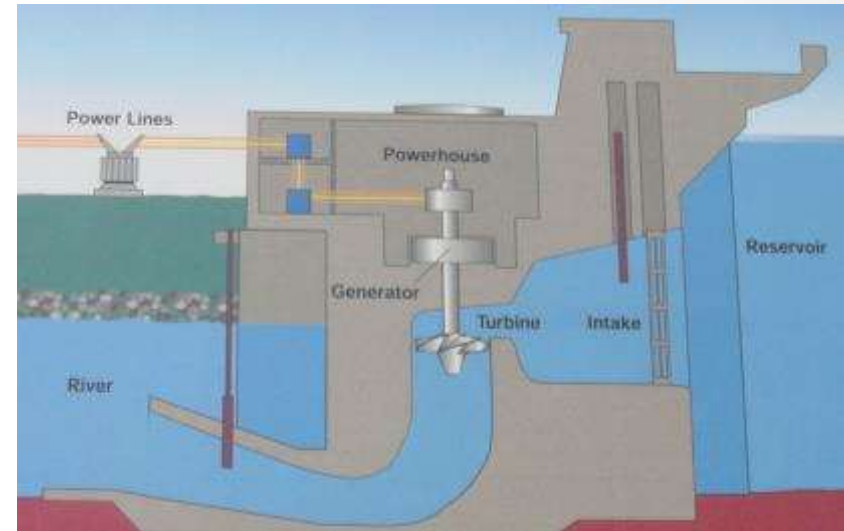

Windmill



Wind turbine

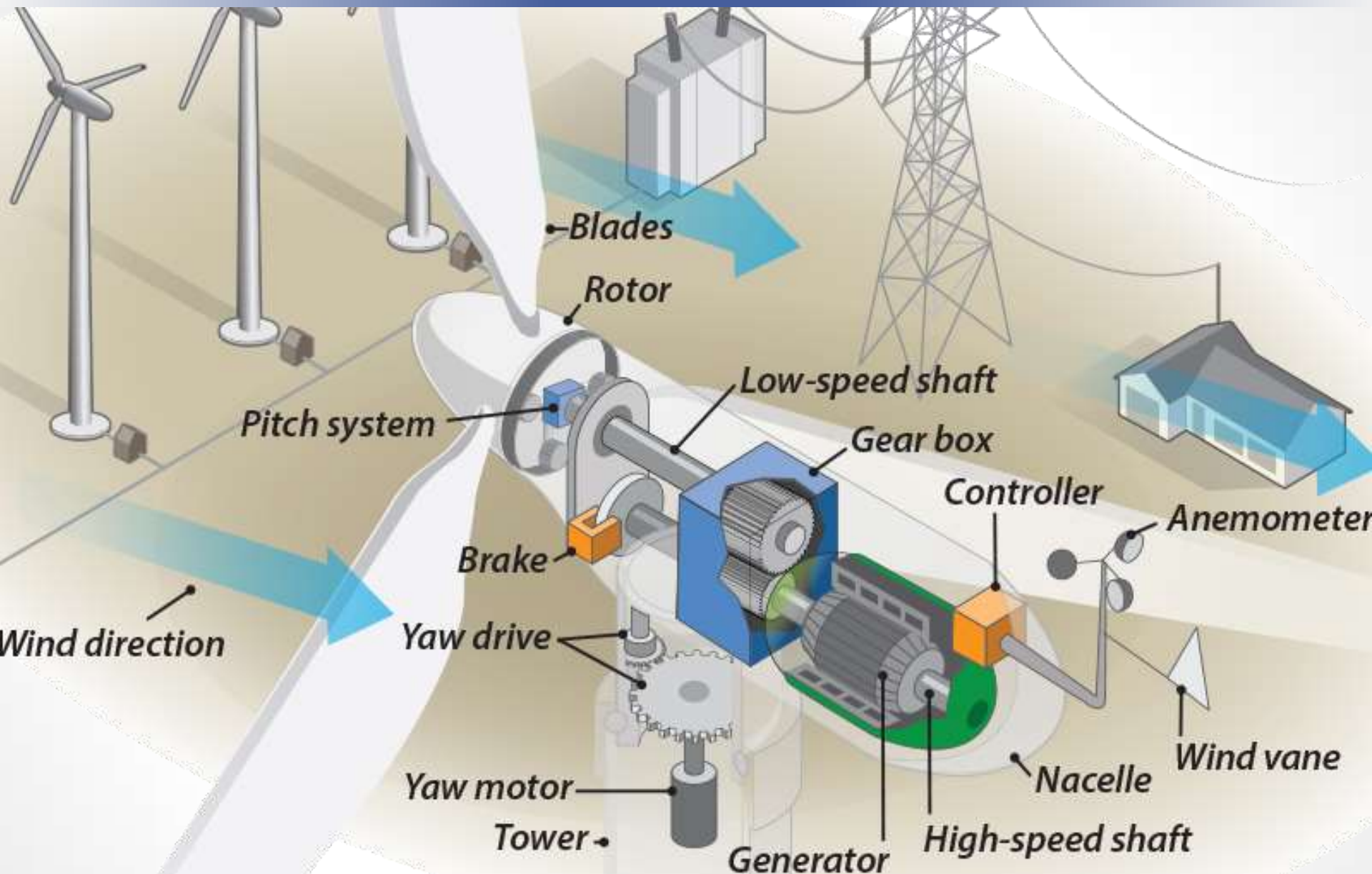

Wind energy



Hand pump

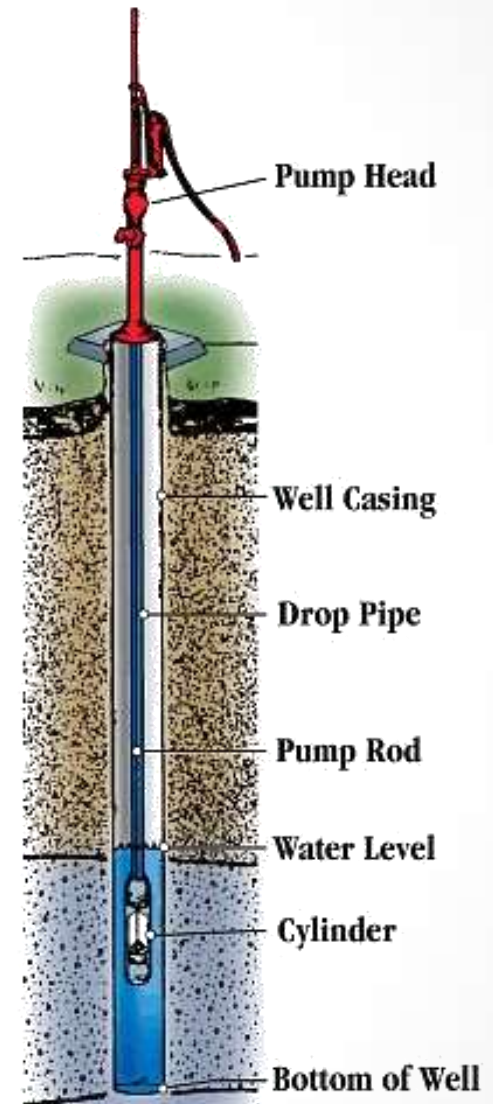
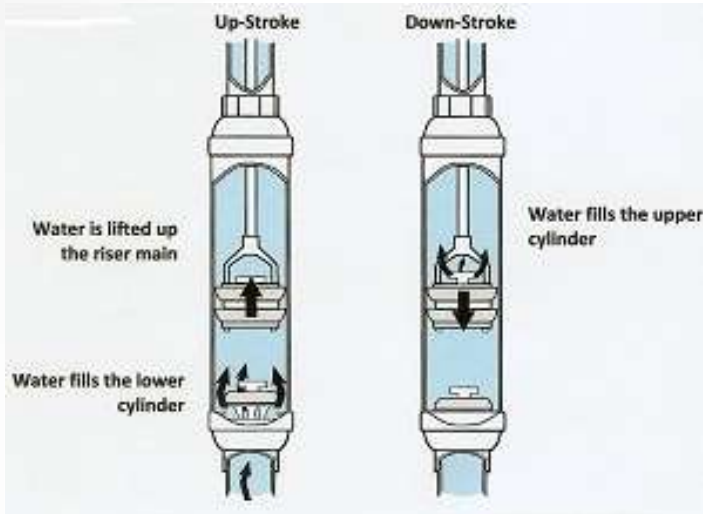

Motor pump

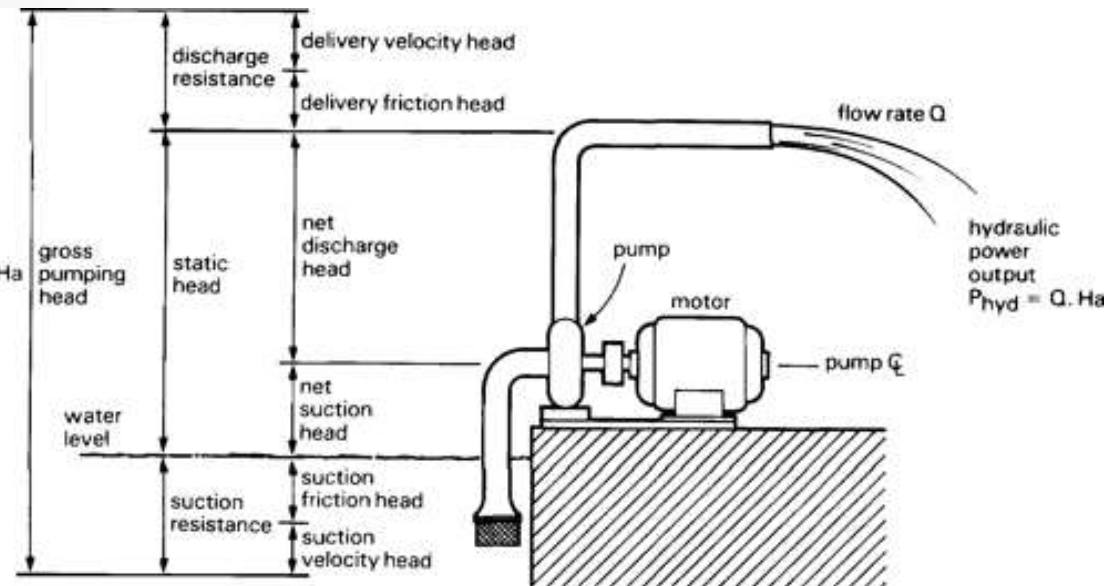

Piping



Heat exchanging

U-tube heat exchanger

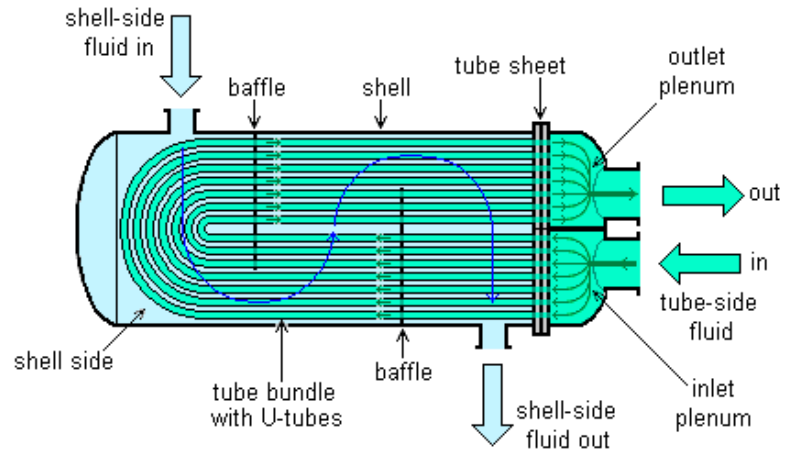

Much smaller and lighter than conventional shell-and-tube designs

Copper-brazed for water, EGW and other common coolants, or nickel-brazed for high purity and corrosive coolants



Extremely efficient herringbone construction for maximum heat transfer

Stainless steel sheets are brazed together at the edges and at a matrix of contact points for a reliable and rugged part



Internal view of liquid-to-liquid brazed plate heat exchanger



Heat, Ventilation and Air Conditioning (HVAC)



Thrust



Internal combustion engines

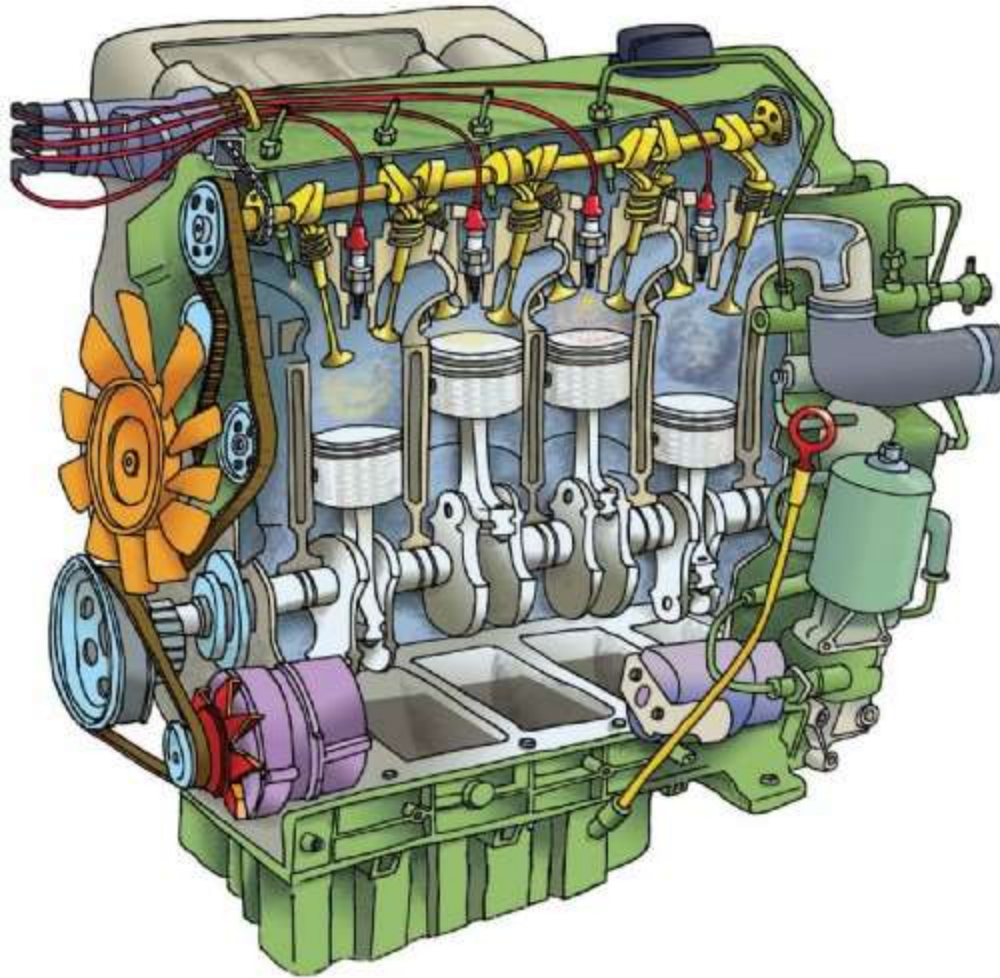

Turbo machinery

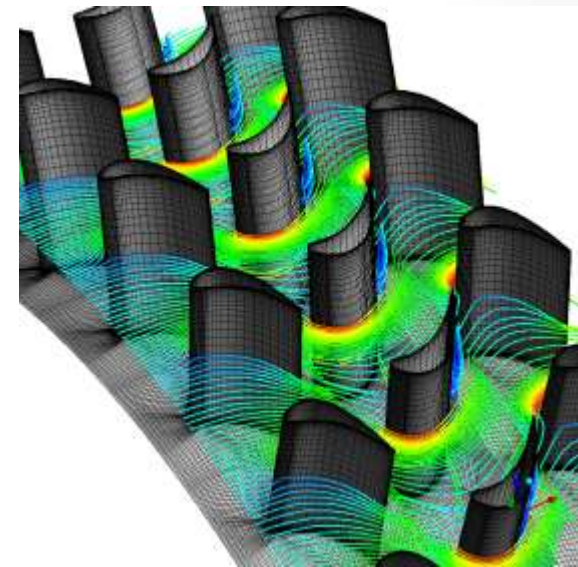
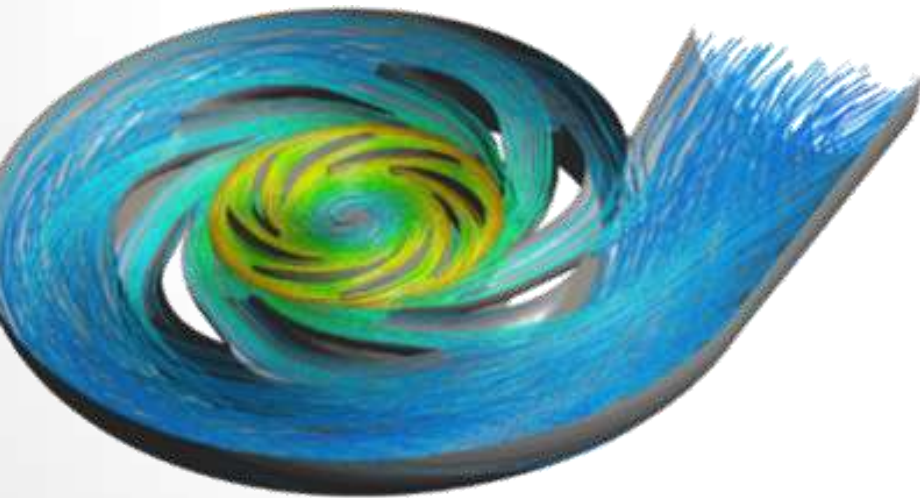
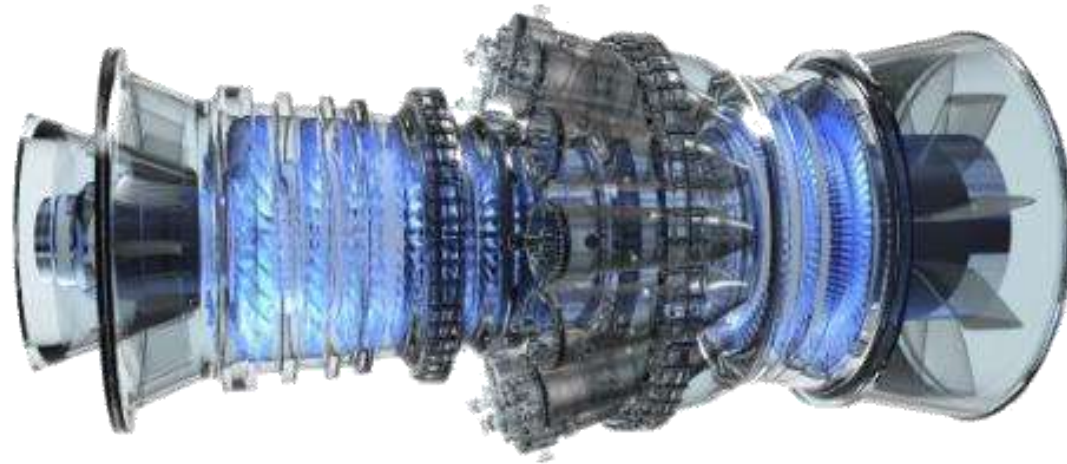

A simple mistake: Mars Climate Orbiter

- On September 23, 1999, communication with the spacecraft was lost as the spacecraft went into orbital insertion, due to ground-based computer software which produced output in non-SI units of pound-seconds (lbf s) instead of the SI units of newton-seconds (N s) specified in the contract between NASA and Lockheed. The spacecraft encountered Mars on a trajectory that brought it too close to the planet, causing it to pass through the upper atmosphere and disintegrate.

Mars Climate Orbiter

